



MTV-1000 Specifications & Options

ENGINE

- Tier 3, Caterpillar® C9, 300 hp (224 kW) @ 2,200 rpm

WEIGHTS

- 50,500 lbs (22,906 kg)

COOLING SYSTEM

- Dual, quiet operation fans

ELECTRICAL SYSTEM

- Standard system includes heavy-duty 90 amp alternator, 24v starting system and circuit breaker protection of all systems.

PROPEL SYSTEM

- Hydrostatic drive
- Continuously variable speed control with two speed ranges.

SPEED

- Maximum working speed: 2.3 mph (3.7 kph)
- Maximum speed (travel range) 9.6 mph (15.4 kph)

BRAKE SYSTEM

- Hydrodynamic disc caliper brakes, and parking brake

TIRES

- Rock Lug - 17.5" x 25" (444.5 mm x 635 mm).

OPERATOR STATIONS

- Operator positions on both sides.
- Control panel swivels for use from either station allowing for same-lane or adjacent-lane operation from either side.

FUME EXTRACTION SYSTEM

- FXS® fume extraction system

TRUCK DUMP HOPPER

- Front hopper has swivel support casters. Vibrating floor plate. 9'2" (2,794 mm) wide truck opening (adjustable width option available).
- Hydraulic, adjustable push rollers.
- Hydraulic front hopper baffle adjustable for optimal material flow.

DUMP HOPPER TRANSVERSE AUGER

- 22" (559 mm) o.d. cast, segmented auger.

DUMP HOPPER UNLOADING CONVEYOR (C1)

- Drag conveyor with 600 tph (544 mtph) capacity.
- Dual roller bushing chain.
- Heavy-duty flights 5/8" (16 mm) thick, 5 9/16" (142 mm) wide, and 33 3/4" (857 mm) long

PAVER LOADING CONVEYOR (C3)

- Drag conveyor with 600 tph (544 mtph) capacity.
- Dual roller bushing chain.
- 1/2" (12.7 mm) thick, 4 3/4" (121 mm) wide and 30" (762 mm) long.
- 500 BHN bolted replaceable floor plates and doors.
- Controls interlock with surge bin unloading conveyor.
- Conveyor can be positioned up to 55° to either side of center.
- Conveyor guard rails.

HOPPER INSERT

- An optional mass-flow paver hopper insert is used to increase the hopper capacity of a conventional paver when used with the MTV-1000.

SERVICE CAPACITIES

- Fuel Tank150 gal (568 l)
- Hydraulic Fluid Tank.....80 gal (303 l)

OPTIONS

- Windrow attachment
- Hydraulic generator set
- Hopper insert
- Light package
- Triple pitch augers in dump hopper

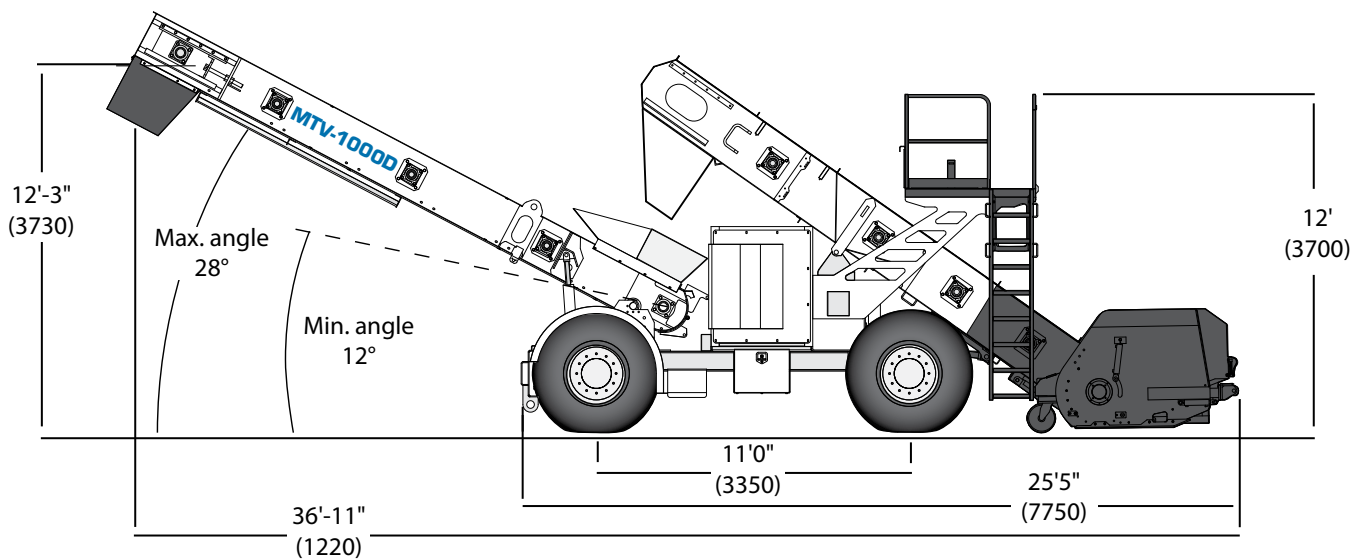
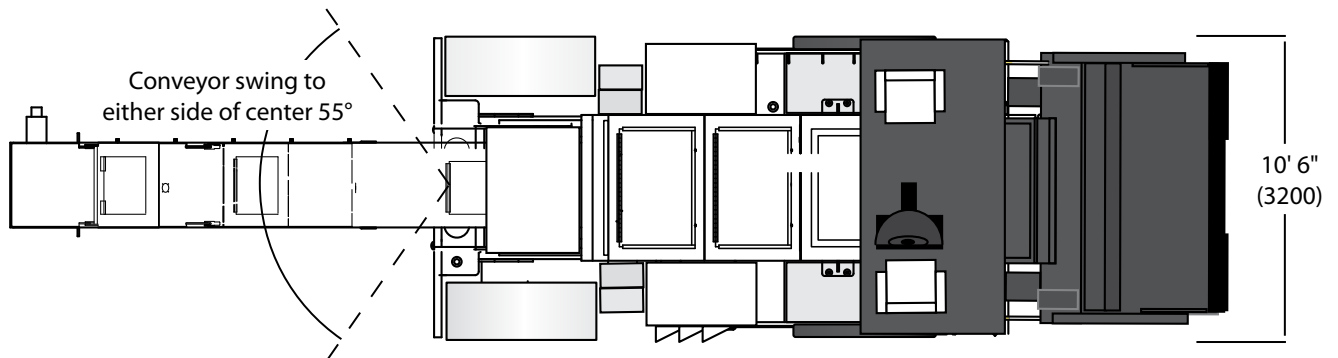

Dimensions in brackets are mm.

Specifications are subject to change without notice.

ROADTEC an Astec Industries Company

800 MANUFACTURERS RD • CHATTANOOGA, TN 37405 USA • 800.272.7100 • FAX 423.267.7104 • roadtec.com

130307



© 2013 Roadtec, Inc. All Rights Reserved